

VW Model 181 Wiring Diagram

APRIL 1973 - NORTH AMERICAN VERSION

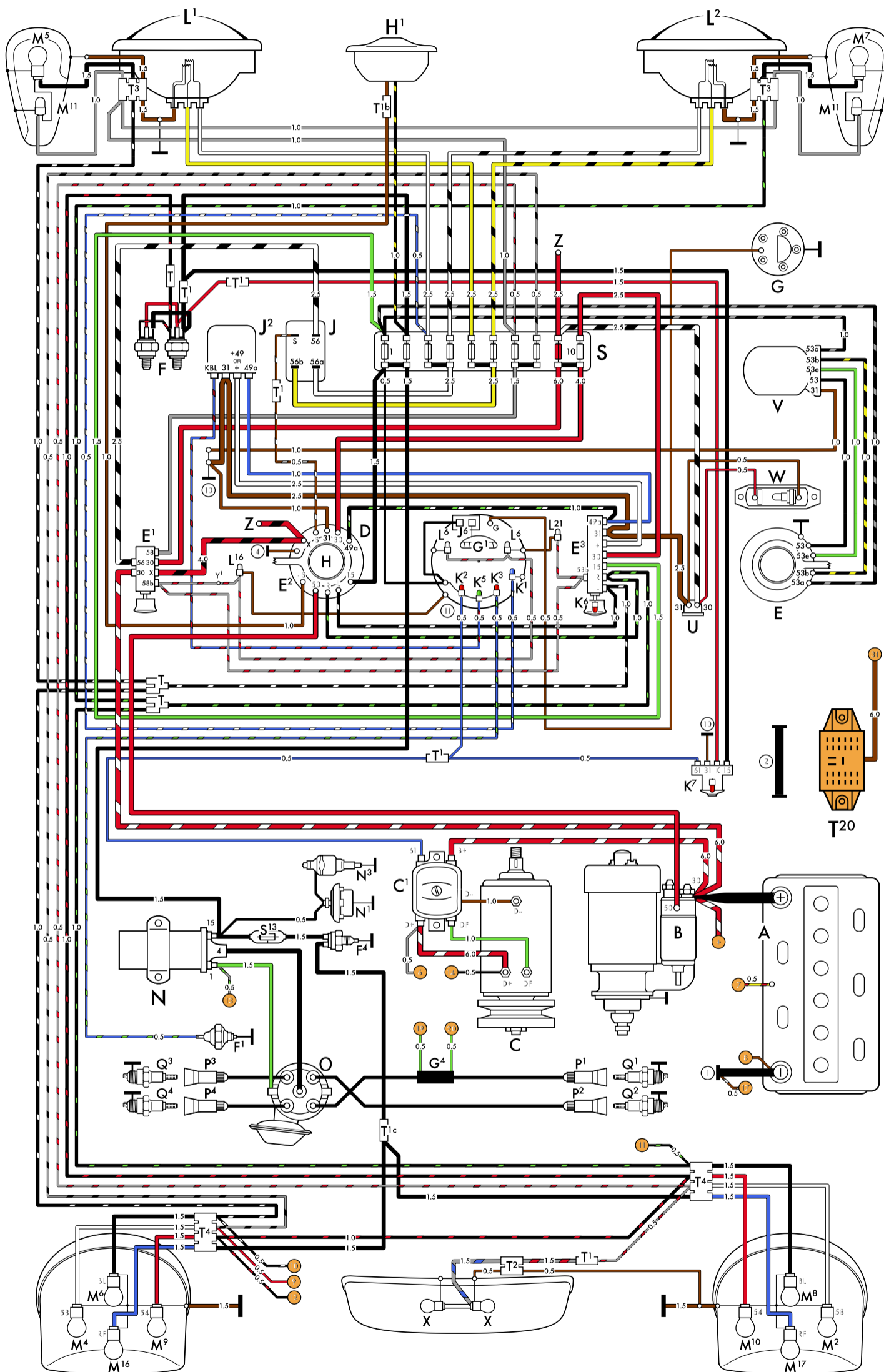

- A — Battery
 - B — Starter
 - C — Generator
 - C¹ — Voltage regulator
 - D — Ignition/starter switch
 - E — Windshield wiper switch
 - E¹ — Light switch
 - E² — Turn signal switch and headlamp dimmer switch
 - E³ — Emergency flasher switch
 - F — Brake lamp switch
 - F¹ — Oil pressure switch
 - F⁴ — Backup lamp switch
 - G — Fuel gauge sending unit
 - G¹ — Fuel gauge
 - G⁴ — Ignition timing sensor
 - H — Horn switch
 - H¹ — Horn
 - J — Headlamp dimmer relay
 - J² — Emergency flasher relay
 - J⁶ — Fuel gauge vibrator
 - K¹ — High beam indicator lamp
 - K² — Generator warning lamp
 - K³ — Oil pressure warning lamp
 - K⁵ — Turn signal indicator lamp
 - K⁶ — Emergency flasher warning lamp
 - K⁷ — Dual brake circuit warning lamp
 - L¹ — Sealed beam unit, left headlamp
 - L² — Sealed beam unit, right headlamp
 - L⁶ — Speedometer lamp
 - L¹⁶ — Heater lamp
 - L²¹ — Heater Lever Illumination lamp
 - M² — Tail lamp, right
 - M⁴ — Tail lamp, left
 - M⁵ — Turn signal lamp, left front
 - M⁵ — Parking lamp, left front
 - M⁶ — Turn signal lamp, left rear
 - M⁷ — Turn signal lamp, right front
 - M⁷ — Parking lamp, right front
 - M⁸ — Turn signal lamp, right rear
 - M⁹ — Brake lamp, left
 - M¹⁰ — Brake lamp, right
 - M¹¹ — Side marker light, front left and right
 - M¹⁶ — Backup lamp, left
 - M¹⁷ — Backup lamp, right
 - N — Ignition coil
 - N¹ — Automatic choke
 - N³ — Electromagnetic pilot jet
 - O — Distributor
 - P — Spark plug connectors
 - Q — Spark plugs
 - S¹ - S¹⁰ Fuses (in fuse box)
 - S¹³ — Fuse, backup lamp (8A)
 - T — Wiring connector behind instrument panel
 - T¹ — Wire connector, single:
 - behind instrument panel
 - in engine compartment, right side
 - T^{1b} — in luggage compartment
 - T^{1c} — in engine compartment
 - T² — Wire connector, double; in engine compartment lid
 - T³ — Wire connector, triple, in headlight housings, left and right
 - T⁴ — Wire connector, quad, below tail light assy's in engine compartment, L & R
 - T²⁰ — Test network socket
 - U — Accessory socket
 - V — Windshield wiper motor
 - W — Interior light
 - X — License plate light
 - Y¹ — Terminal 58b of heater switch
 - Z — Connection for add-on heater
-
- ① Ground strap from battery to body
 - ② Ground strap from gearbox to body
 - ④ Ground strap via steering coupling
 - Ⓧ Ground point, instrument panel
 - Ⓨ Ground point, speedometer
-
- Test Network:**
 The numbers in the orange colored circles correspond with numbered terminals on the diagnostic test connector (T²⁰).